

NAME

Folding T-Shirts - Advanced

DESCRIPTION: The student will use a folding board to fold adult sized shirts (qty. 20). This is a timed event to see who can fold shirts the fastest and with the best quality of work. There is a 5 minute time limit.

Scoring sheet

5 - Excellent	4 - Good	3 - Average	2 – Below Average	1 - Poor	0 – Not Demonstrated
----------------------	-----------------	--------------------	--------------------------	-----------------	-----------------------------

*Handshake scoring

5 – Firm Handshake	3 – Too firm or too soft handshake	0 – No Handshake
---------------------------	---	-------------------------

**Introduction & Thank you

5 – Uses judge’s name	3 – Does not use judge’s name	0 – Not Demonstrated
------------------------------	--------------------------------------	-----------------------------

		Scoring	5	4	3	2	1	0
1	Student introduces self to judge	5 yes	-	-	-	-	-	0 no
2	Student states name of judge in introduction**	5 yes	-	-	-	-	-	0 no
3	Student shakes judge’s hand*	5	-	3	-	-	-	0
4	Student places shirt face down	5	4	3	2	1	0	0
5	Student folds the bottom of the shirt to be even with the bottom of the folding board.	5	4	3	2	1	0	0
6	Flipped panel A to center and back	5	4	3	2	1	0	0
7	Flipped panel B to center and back	5	4	3	2	1	0	0
8	Flipped panel A to center and back to fold sleeve in.	5	4	3	2	1	0	0
9	Flipped panel C to center and back	5	4	3	2	1	0	0
10	Shirt is neatly folded	5	4	3	2	1	0	0
11	Adds shirt neatly to the stack of shirts.	5	4	3	2	1	0	0
12	Student shakes judge’s hand*	5	-	3	-	-	-	0
13	Student thanks judge using judge’s name**	5	-	3	-	-	-	0

Time completed in 5 minutes or less. Entered in min:sec (EX 4:55, 2:10) _____:

Judges: All 13 questions and the total time MUST be entered into spreadsheet.

Shirt folding Tips and Advice

When flipping and folding, move the boards quickly and firmly - this allows for a flat, neat fold, getting all the air out.

How to Fold a T-Shirt - Basic Shirt Folding

Follow these t-shirt folding instructions for help when folding t-shirts and short sleeved shirts.

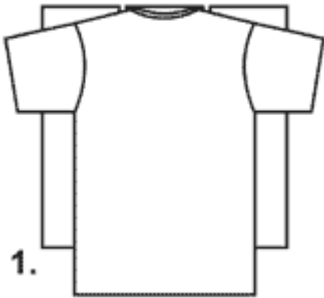

Open shirt face down (Logo face down) on the Flip FOLD shirt folder.

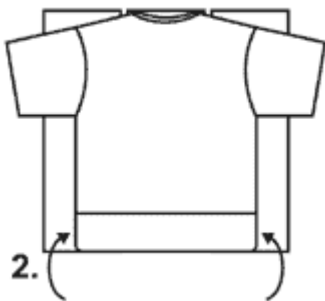

Fold bottom of the shirt even with the bottom edge of shirt folding board.

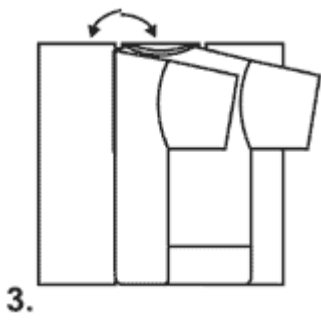

3.

Flip panel A to center and back.

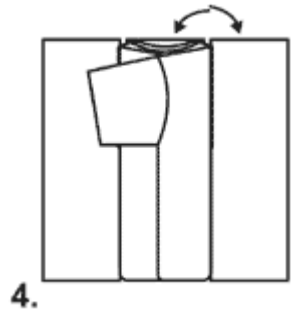

4.

Flip panel B to center and back.

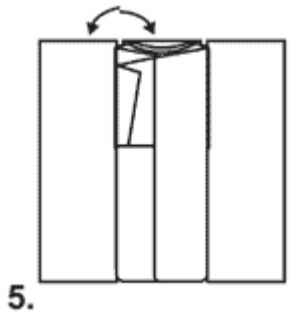

5.

Flip panel A to center and back. (flipping sleeve in)

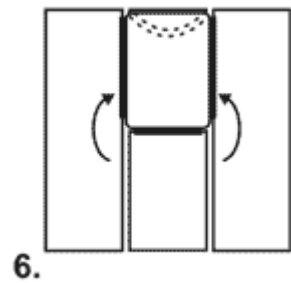

6.

Flip panel C up to center and back.